



Consulting, help, relaxation

INTERNATIONAL JOURNAL OF ENGINEERING SCIENCES

&amp;

MANAGEMENT

**STUDY AND ANALYSIS OF A NOVEL SMART ANTENNA IN WIRELESS LAN COMMUNICATION SYSTEM****\*Prof. G.R Prajapati, <sup>1</sup>Prof. K.C. Mahajan**<sup>\*</sup>Alpine Institute of Technology, Ujjain (M.P), India<sup>1</sup>Acropolis College of Science and Technology, Bhopal (M.P.), India**ABSTRACT**

The adoption of smart antenna techniques in future wireless systems is expected to have a significant impact on the efficient use of the spectrum, the minimization of the cost of establishing new wireless networks, the optimization of service quality, and realization of transparent operation across multi technology wireless networks. A novel smart antenna is described, which is conceived as a low complexity inexpensive upgrade for IEEE 802.11b/g Wireless Local Area Network (WLAN) systems. Using smart antennas to increase network throughput by improved spatial reuse is not normally possible for systems using the 802.11 Medium Access Control (MAC), unless centralized channel access control is enforced. However, it is shown through simulation that the proposed antenna can have sufficient beam and null steering capabilities to allow two 802.11g transmissions to co-exist in close proximity. This is achieved with the standard distributed channel access algorithms and therefore has potential to increase system capacity. Accuracy in simulation is ensured through a combination of MAC functionality modeling using OPNET and 3- dimensional (3D) propagation modeling using ray tracing.

**INTRODUCTION**

The development of a truly personal communications space will rely on the design of next generation wireless systems based on a whole new concept of fast, reconfigurable networks, supporting features such as high data rates, user mobility, adaptability to varying network conditions, and integration of a number of wireless access technologies, and offering new user-centric flexible service paradigms, relying on the exploitation of new resources such as cross-layer and contextual information.

This paper describes the evaluation of a low cost novel smart Antenna for use with a Wireless Local Area Network (WLAN). The design of the antenna allows it to be implemented as an inexpensive practical enhancement to readily available WLAN equipment. The benefits of smart antennas are well known, and include the ability to optimize transmit and receive antenna gains for a particular location and thus to offer improved coverage. For systems where channel access is centrally regulated, such as cellular mobile communications or HIPERLAN/2WLANs, smart antennas are also able to offer an increase in capacity by allowing efficient spatial reuse of a frequency channel. However, the distributed

**Corresponding Author\***

Email- girirajp@yahoo.com

nature of channel access in a 802.11 WLAN system means that the possibility of achieving spatial reuse using smart antennas is limited unless modifications to the standard Medium Access Control (MAC) protocol are made. This is due to the impossibility of every WLAN node being able to optimize its own smart pattern to minimize the interference to every other interfering node while maintaining optimum signal strength to wanted nodes. This is particularly challenging in the indoor environments in which WLAN systems operate, where propagation conditions create a large spread of angles of arrival. The novelty of this work is that the antenna is optimized to operate in a multipath environment with a high angular spread. This is achieved by implementing a sufficient variety of null and peak beam characteristics to permit spatial reuse, even when a distributed channel access scheme is used. These characteristics allow enough rejection of interfering signals and enhancement of wanted signals to provide an increase in throughput for an 802.11b/g system. This work concerns the use of the antenna as tool to improve coverage and capacity in 802.11g WLAN networks. However the antenna could also find applications in high data rate home audio/video distribution networks or to facilitate connectivity in multi-hop mesh networks.

#### **ANTENNA**

The concept of the smart antenna is to provide a simple upgrade path for existing 802.11 products; this rules out any design that would require the modification of hardware or functionality, in particular the Medium Access Control (MAC) protocol. The smart antenna array comprises 9 individual elements. The basic antenna

element is a dual band trident monopole, which consists of a low frequency central element in parallel with two linked higher frequency elements as shown in Figure 1. The antenna element is manufactured on 1.6mm FR4 substrate material, which has a permittivity of 4.4 and a loss tangent of 0.02. The measured return loss for the antenna is shown in Figure 2. The antenna has been designed primarily to operate over the WLAN frequency band of 2.4 to 2.5 GHz, but also exhibits a 10 dB return loss over the 4.9 to 6.3 GHz band. The array consists of a single active trident monopole element, surrounded by eight passive elements. The surrounding passive elements can be made effectively visible or invisible by shorting their inputs to ground, or not. This allows 256 switch states, each corresponding to a unique 3D pattern. The design of the array uses full 3D electromagnetic models along with circuit equivalence models for the switching device. The effect on the radiation patterns of the non-ideal behavior of the switching devices has been taken into account in the modeling. The performance of the array has been optimized from the system perspective. The optimum array configuration was refined using 3D ray tracing simulations in combination with predicted patterns to maximize the predicted Signal to Interference Ratios (SIR) between four nodes equipped with smart antennas in several realistic indoor environments. One of the parameters optimized was the radial spacing of the array, which was found to be  $\lambda/3$  at 2.462 GHz for the environment considered. The finalized optimum design was manufactured as a prototype for fitting onto an off-the-shelf WLAN Access Point (AP). This arrangement can be seen in Figure 3. The antenna elements are mounted

on a two sided PCB. The upper side of the PCB acts as the antenna ground plane whereas the lower face contains all the control electronics, including RF switches, a Programmable Integrated Circuit (PIC), and an RS232 connection that facilitates a link to a control PC for performance measurement. To verify the performance of the completed smart array, radiation pattern measurements were performed on a spherical near field facility at 2.462 GHz. The measured gain for 3 of the 256 possible array states are shown in Figure 4. The main beam can be controlled in azimuth with a maximum gain of 5.75 dBi. Multiple beam lobes and nulls can also be formed with peak to null discriminations of up to 10 dB.

It is envisaged that the prototype would be further enhanced by reducing the size and orientation of the antenna elements to offer a more compact upgrade to a WLAN Access Point (AP). Control of the antenna switching would be integrated into the AP functionality.

## **802.11 MAC WITH SMART ANTENNAS**

### **A. 802.11 MAC**

The operation of the 802.11 MAC doesn't easily facilitate the usual benefits of smart antennas offered by spatial filtering for interference rejection. Several authors have proposed alternative "directional MAC" algorithms. The vast majority of 802.11 WLAN networks operate with a MAC using Distributed Co-ordination Function (DCF), meaning that the nodes in a particular radio environment must contend for channel access amongst themselves.

The 802.11 MAC is a Carrier Sense Multiple Access (CSMA) design with Collision Avoidance (CA) [4]. An optional "Request to Send" and "Clear to Send"

(RTS/CTS) exchange between data source and destination prior to data transfer can ensure that all nodes using the channel that could be affected by both nodes involved in the impending transmission are themselves inhibited from channel access, solving the so-called hidden node problem. Packets sent are acknowledged by an ACK packet sent back from the traffic destination to the source. Wireless networks, such as 802.11, are prone to the hidden node and exposed node effects, created by the potential inability of the CSMA process to detect other nodes that may suffer from, or cause interference to, an impending transmission.

### **B. Smart antenna issues**

The CSMA/CA protocol and RTS/CTS exchange are optimized to operate with mainly static equipments with fixed coverage from omni-directional antennas. They do not work well when coverage patterns from antennas can change, as in a system using smart antennas, with the potential to create many hidden and exposed nodes. One problem is considered in Figure 5 where two Nodes A and C wish to transmit simultaneously to Nodes B and D respectively using the same physical 802.11g channel. The normal operation of the MAC would be for the CSMA process resident in Nodes A and C to detect each others transmissions and to share channel access fairly, resulting in each of them being able to achieve a throughput of around half the maximum. The aim of the spatial reuse achievable by a smart antenna is to allow the CSMA process of each link to be "deafened" to the presence of the other transmission, allowing both links to operate at near the full available throughput. The aim of the results presented in this paper is

demonstrate that the smart antenna has a sufficient number of diverse patterns to select from to be able to (i) maximize the SIR and (ii) ensure that the power of interfering packets is attenuated sufficiently to be ignored by the MAC process.

### **C. Propagation Issues**

WLAN systems are generally required to operate in indoor environments characterized by multipath activity causing a wide spread of angular arrival. The simplest form of spatial filtering would be for a WLAN node to use its smart antenna to direct a beam aligned towards its partner node. However, this is not likely to prove effective in a strong multipath environment, as the beam width may (i) include a strong ray from an otherwise interfering source and (ii) discount a strong wanted ray arriving from a widely separated angle from the bore sight of the antenna. The challenge of the smart antenna system presented in Figure 3 would be for the nodes to achieve the required amount of interference attenuation, even when the multipath environment means that the interference will have a wide angular dispersion.

## **SIMULATION METHOD**

### **A. Modeling**

In order to test the throughput achievable by the smart antenna, a simulation was conducted using the OPNET package.

The simulation took advantage of the inbuilt 802.11 MAC models, and traffic generation capability provided by OPNET, but was also enhanced to use ray tracing propagation predictions produced for a particular environment (replacing the standard OPNET radio channel models). The ray tracing data was available to model the room, provided in the form of a database containing multiple possible propagation paths available

between arbitrary points. The technique used to produce the data is described in . The data for each ray path comprised the complex field strength for a normalized power output plus the 3D angle angles of departure and arrival from the source and destination respectively. An aggregate transmission loss between any two points in the simulated environment could therefore be achieved by combining the gains of the transmitting and receiving antenna at the appropriate angles with the path loss for these values.

$P_{total} = \sum_{n=1}^N P_n G_t(\theta_d(n), \phi_d(n)) G_r(\theta_a(n), \phi_a(n))$  (1) The received power  $P_{total}$  is as given in Equation 1 where  $N$  is the total number of rays between two points;  $\theta$  and  $\phi$  are the 3D angles of departure from the transmitter and arrival at the receiver respectively and  $G_t$  and  $G_r$  are the transmitter and receiver gains at these angles. The power of the  $n$ th ray, normalized for an isotropic radiator, is given by  $P_n$ . The simulation platform was therefore able to take advantage of accurate predictions for wanted and interfering signal powers for WLAN nodes in any location using any combination of smart antenna patterns.

### **B. Environment**

The environment used for the simulations was a large open plan office (approx 18m x 12m) in Merchant Venturers 'Building, University of Bristol. A plan of the environment is given in Figure 6. The environment simulated is typical of a large indoor office with challenging multipath propagation. It is sub divided into individual cubicles by low height dividers. There are 4 supporting pillars and a number of metal cupboards. Two Access Points (AP1 and AP2) are located at ceiling height and two user terminals (STA1 and STA2) at desk height.

**C. Methodology**

The overall benefit of the antenna lies in its ability to offer an increase in throughput; the general aim of the various simulations conducted is therefore to demonstrate an improvement in the aggregate throughput achievable for a particular scenario. Each scenario is constructed with two Access Points (APs) simultaneously transmitting on the same frequency channel, each AP being configured to transmit to a particular user station (STA). In order to test the throughput, each individual link is configured to send packets to achieve the maximum end-to-end throughput; for an 802.11g link operating in the absence of interference in the fastest available mode, this is around 24Mbps. The simulation parameters used to achieve this corresponded to a fixed packet size of 1500 bytes, generated at a constant rate of 2083s<sup>-1</sup>. Any interference would normally cause packets to be dropped. RTS/CTS handshaking is turned off, as is common practice for WLAN deployments. Each AP or STA in the system is configured to use the pattern (from the 256 available) that maximizes the wanted signal from its “partner” STA or AP, while minimizing the interference from the other units. For the purpose of the simulation, this pattern is chosen through a brute force method of attempting all pattern combinations; for a practical implementation, a more sophisticated approach would be necessary

**TABLE I  
ANTENNA CONFIGURATIONS AND CODES**

Code	AP1	STA1	AP2	STA2
S S S S	smart	smart	smart	smart
O O O O	omni	omni	omni	omni
S O S O	smart	omni	smart	omni
O O S S	omni	omni	smart	smart

(In particular each WLAN unit would need either to select its pattern independently, or participate in a joint decision making process). A successful outcome would be an increase in the aggregate throughput seen in the environment, i.e. exceeding the 24Mbps normally possible. An ideal case would be an aggregate throughput of 48Mbps, meaning that the two links are able to co-exist with their MAC processes unaware of each other.

**D. Antenna Configurations**

Various configurations of smart and omni directional antennas were simulated for each scenario; for convenience in presenting the results, each configuration was given a code, the codes are listed in Table I. The “S S S S” configuration represents the case where all 4 nodes in the test system can be equipped with the smart antenna. The “O O O O” case is where all the nodes have omni-directional antennas; this represents a reference configuration against which performance improvements can be measured. The “S O S O” configuration is a scenario where the STAs (i.e. the user supplied equipment) are equipped with omni-directional antennas, and the APs have smart antennas, as might be a realistic case for a public WLAN deployment. Finally, the “O O S S” is a case where one AP/STA pair has omni-directional antennas, and the other AP/STA pair is equipped with the smart antennas to attempt to counteract the interference.

**RESULTS**

**A. Time varying throughput for two interfering signals**

A 10 second test was conducted, AP1 sending data (to STA1) from a time period of 0–10 sec, while AP2 transmitted (to STA2) from 5–10sec; the two transmissions were therefore mutually interfering for half of the

available transmission period. Transmit powers of 100mW were used. Figure 7 shows the aggregate throughput that can be achieved in this scenario. Throughput is measured as the rate at which correctly received packets are processed at the STA; the aggregate throughput is the sum of these values for STA1 and STA2. The “S S S S” and “O O O O” cases are plotted. It can be seen that in the absence of interference (i.e. between 0 and 5 seconds) the single link is able to sustain maximum throughput. When the second link is activated (at 5sec) the tendency of the MAC process to share access to the channel causes a small drop in throughput for the case where the conventional omni directional antennas are used. However, the smart antenna is able to permit an increase in the total throughput (of approximately 14%) suggesting that the intended goal of being able to support simultaneous packet transfer over two links is being achieved. The variability in the rate of traffic transmission is due to the random back off before transmission which occurs if the medium is busy at the desired transmission time. In the “S S S S” case, maximum throughput is possible in the absence of interference (i.e. for the first 5seconds), however the “O O O O” case is unable to offer any throughput. The reduced power has the effect of offering further isolation between the users, and so the throughput improvement seen by using optimized smart antennas is more dramatic. In the case where smart antennas are used, the global throughput is around 48Mbps, meaning that two links are able to operate at full throughput without mutual interference (i.e. an ideal result for the antenna scenarios). Where omni directional antennas are used (at one or both ends of each link),

there is no throughput for one of the links even in the absence of interference, implying that the STA is out of range of the AP. The action of the smart antennas in this case could be considered as providing increased throughput by offering improved coverage to units that would otherwise not be served (either as fill-in coverage, or by extending coverage boundaries).

### ***B. Throughput summaries for two interfering signals***

Further simulations were carried out using the antenna configurations given in Section IV-D. In each case, the aggregate throughput was averaged over the time period during which the two links were interfering. For reference, the values from the previous scenario are plotted too. The results are given in Figure 9, power outputs of 1mW, 10mW and 100mW were considered. The low power “S S S S” configuration has the best aggregate throughput by a large margin; particularly compared to the reference “O O O O” configuration for 1mW power output. Smaller throughput improvements are also seen for the “S O S O” and “O O S S” cases, which could be considered as being more realistic deployments as they take away the requirement for both WLAN provider and user to be equipped with the smart antenna. The results for the 1mW output are in fact worse than the 10mW and 100mW for all configurations, with the exception of the “S S S S” case, possibly confirming that the network is in this case unable to provide coverage with such low powers without the additional gain provided by the smart antennas. An additional simulation scenario was created, this was similar to the first one, but the positions of the STAs were exchanged. This was predicted to be a more challenging scenario as any advantage due

to the proximity of the AP to its partner STA would be removed. Such an advantage might be the low correlation between the angle of arrival of wanted and interfering signals. Results are once again provided for power outputs of 1mW, 10mW and 100mW. It should be noted that throughput is 0 for the 1mW case. It can be seen that the smart antenna offers no benefit in this case; for the lowest power output no packet transfer is possible. For all the other antenna configurations, the throughput is restricted to the reference value.

### CONCLUSION

The work presented in this paper has shown that the smart antenna array presented can, under certain circumstances, improve aggregate throughput by allowing two 802.11g transmissions to co-exist each using their maximum rate. This is achieved by desensitizing the MAC process that would normally inhibit transmission in the presence of an interfering signal. Optimum results are obtained where all the nodes in the network are equipped with the smart antenna. The extent to which the improvement is possible is highly sensitive to the transmit powers used. A challenging multipath environment has been investigated; the antenna solution could be better suited to more benign propagation environments, such as outdoor WLANs or to static networks. The concept through out has been to maintain upgradeability for off the shelf equipment; further improvements could be achievable by use of non standards-

compliant techniques such as adaptive power control or modified MAC algorithms.

### REFERENCES

- [1] Evaluation of a Novel Low Complexity Smart Antenna for Wireless LAN Systems. T.J. Harrold, D.C. Kemp<sup>†</sup>, M.A. Beach, C. Williams, M. Philippakis and M.W. Shelley Centre for Communications Research, University of Bristol Woodland Road, Bristol, BS8 1UB, United Kingdom, Email: Tim.Harrold@bris.ac.uk.
- [2] L. J. Pesik, M. A. Beach, D. P. McNamara and P. N. Fletcher Performance analysis of smart antenna systems for indoor wireless LANs IEE Third International Conference on 3G Mobile Communication Technologies, 8-10 May 2002, pp 418–422.
- [3] S. C. Swales, M. A. Beach, D. J. Edwards and J. P. McGeehan Performance enhancement of multibeam adaptive base-station antennas for cellular land mobile radio systems IEEE Transactions on Vehicular Technology, v 39, n 1, Feb, 1990, pp 56–67.
- [4] R. R. Choudhury and N. Vaidya, H. Deafness: A MAC problem in ad hoc networks when using directional antennas Proceedings of the International Conference on Network Protocols, 2004, pp 283–292.
- [5] B. OHara and A. Petrick *802.11 Handbook A Designers Companion* IEEE Press 1999.
- [6] B.S. Lee, A.R. Nix and J.P. McGeehan Indoor space-time propagation modeling using a ray launching technique Eleventh International Conference on Antennas and Propagation, 2001, pp 279–283AC.

**FIGURES:**

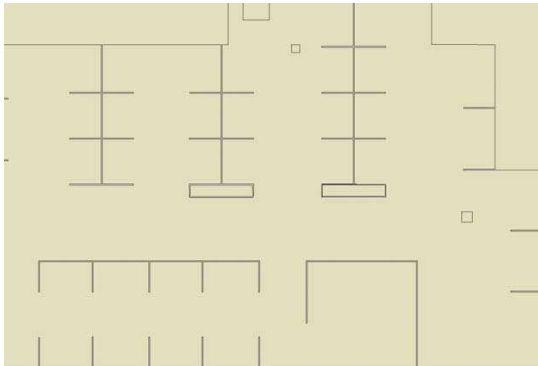

**Fig.1 Environment used for the Simulations (dimensions in meters)**

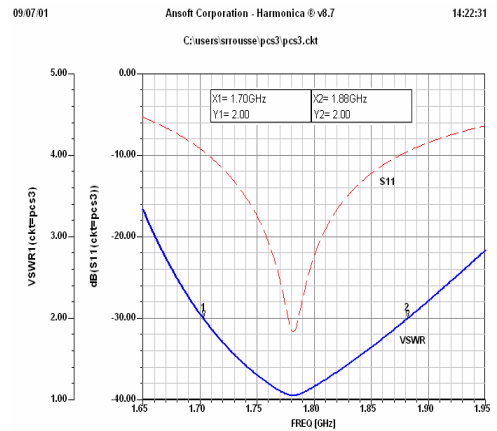

**Fig.3 VSWR/Return Loss**

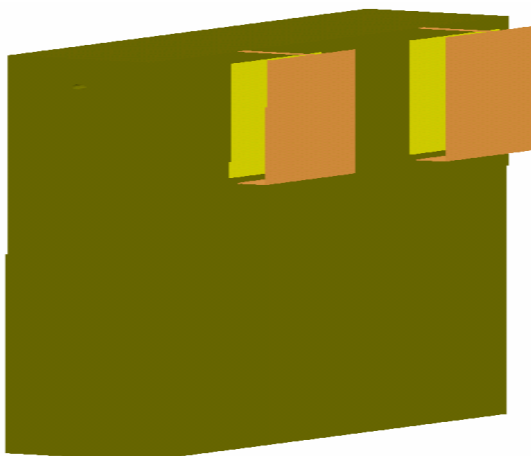

**Fig.2 Geometry sma**

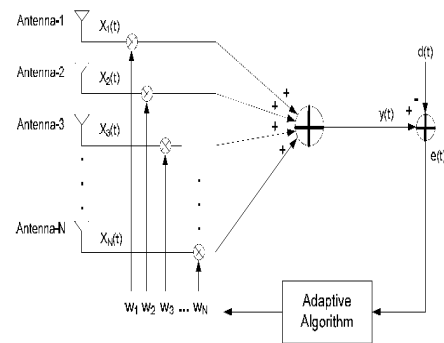

**Fig.4 Adaptive beam-forming block diagram**